



TAI-SAW TECHNOLOGY CO., LTD.

No. 3, Industrial 2nd Rd., Ping-Chen Industrial District,
Taoyuan, 324, Taiwan, R.O.C.

TEL: 886-3-4690038 FAX: 886-3-4697532

E-mail: tstsales@mail.taisaw.com Web: www.taisaw.com

Product Specifications Approval Sheet

Product Name: SAW Resonator 669.694 MHz SMD 3X3 mm

TST Parts No.: TC0413A

Customer Parts No.: _____

Customer signature required
Company: _____
Division: _____
Approved by : _____
Date: _____

Checked by: _____ Hongpu Lin *Hong Pu Lin*

Approval by: _____ Andy Yu *Andy Yu*

Date: _____ 2019/04/25

1. Customer signed back is required before TST can proceed with sample build and receive orders.
2. Orders received without customer signed back will be regarded as agreement on the specifications.
3. Any specifications changes must be approved upon by both parties and a new revision of specifications shall be released to reflect the changes.

TST TAI-SAW TECHNOLOGY CO., LTD.

No. 3, Industrial 2nd Rd., Ping-Chen Industrial District,
Taoyuan, 324, Taiwan, R.O.C.

TEL: 886-3-4690038 FAX: 886-3-4697532

E-mail: ttsales@mail.taisaw.com Web: www.taisaw.com

SAW Resonator 669.694 MHz

MODEL NO.: TC0413A

REV. NO.: 2.0

A. FEATURES:

1. 1-Port Resonator.

B. MAXIMUM RATING:

1. Input Power Level: 0 dBm
2. DC voltage: 3 V
3. Operating Temperature: -40°C to +85°C
4. Storage Temperature: -40°C to +85°C
5. Moisture Sensitive Level (MSL): Level 1

RoHS Compliant
Lead free
Lead-free soldering

C. ELECTRICAL CHARACTERISTICS:

Characteristic	Units	Minimum	Typical	Maximum
Center frequency Fr	MHz	669.654	669.694	669.734
Insertion Loss IL	dB	-	1.39	2.0
Equivalent Elements				
Motional capacitance C1	fF	-	1.29	-
Motional inductance L1	μH	-	43.32	-
Motional resistance R1	Ohm	-	16.91	-
Parallel capacitance Co	pF	-	2.64	-
Temp.coeff.	ppm/c*2	-	0.032	-
Turnover To	deg.C	-	25	-
Package size		SMD 3.0X3.0X1.4mm		

D. EQUIVIRENT CIRCUIT:

One-Port Resonator:

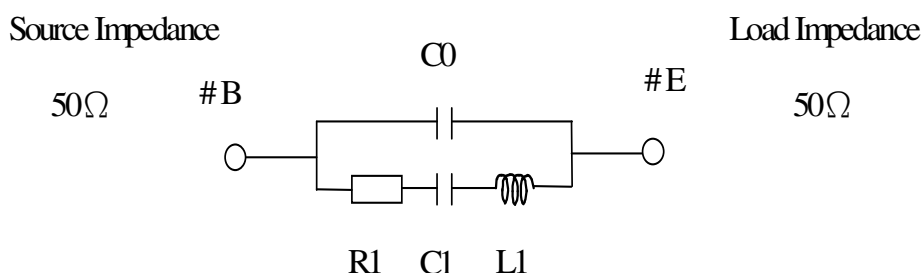

E. OUTLINE DRAWING:

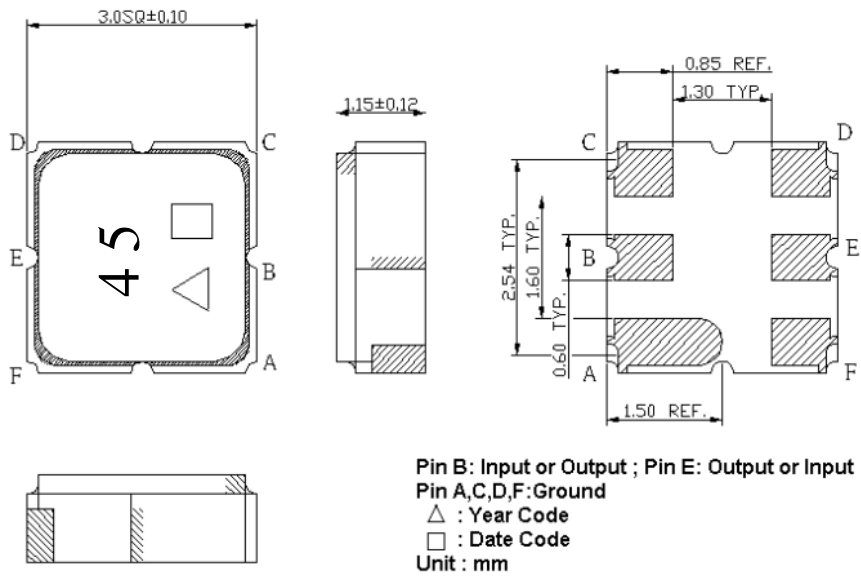

Date code: Provided by planer each year
 Year code: 7 for 2007,8 for 2008,...

F. FREQUENCY CHARACTERISTICS

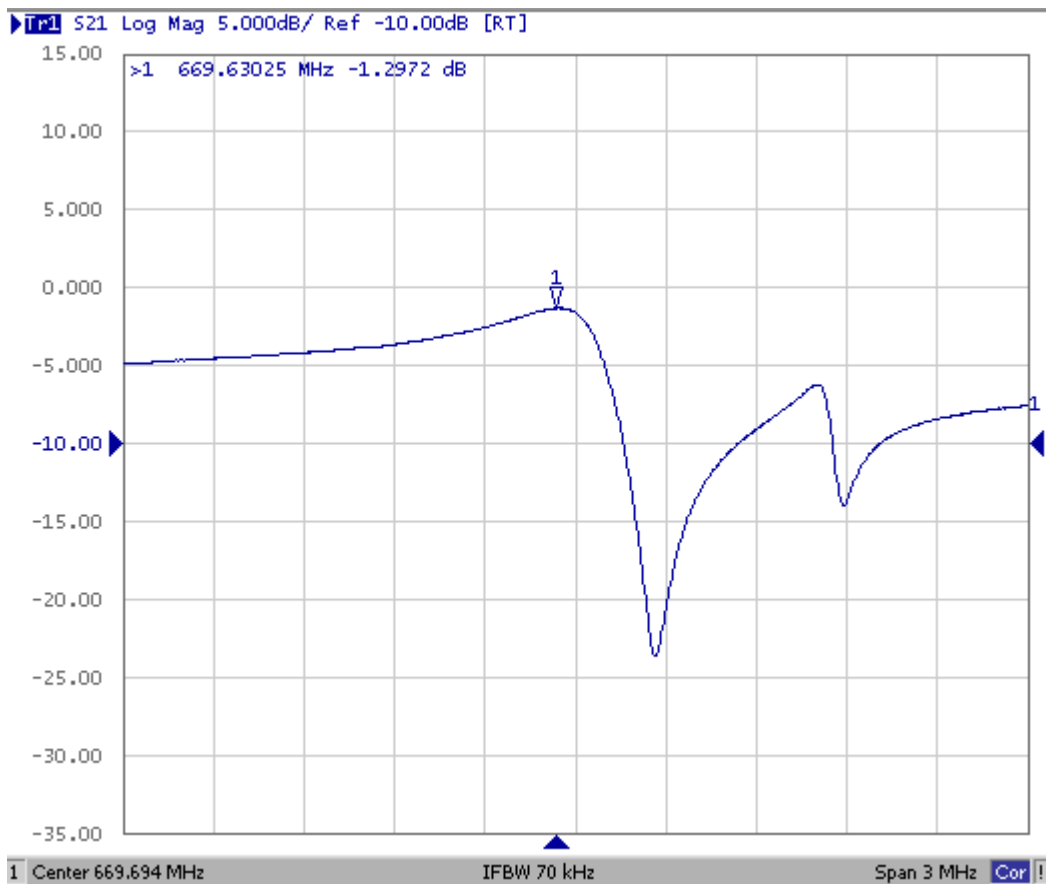

G. TEST CIRCUIT:

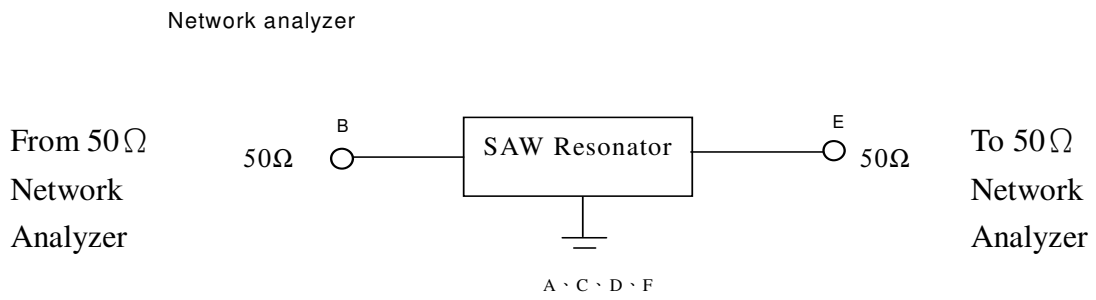

H. LAND PATTERN:

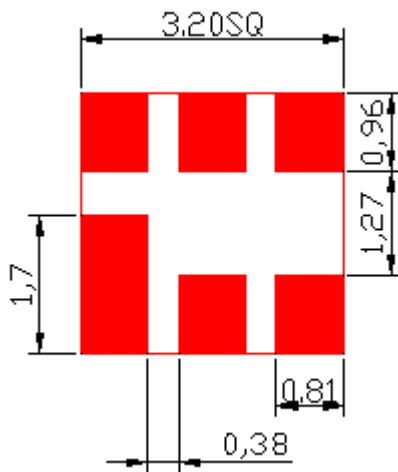

I. PACKING:

1. REEL DIMENSION

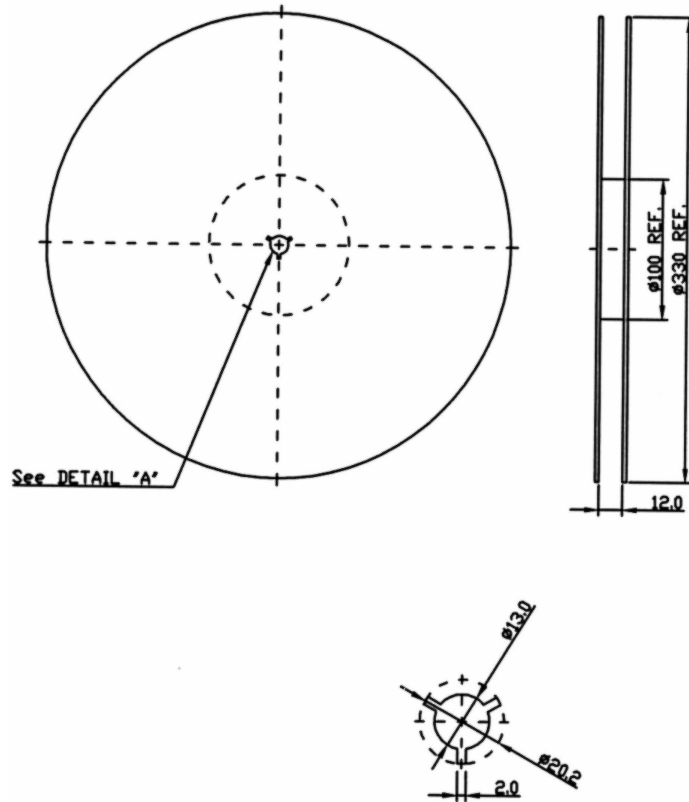

2. TAPE DIMENSION

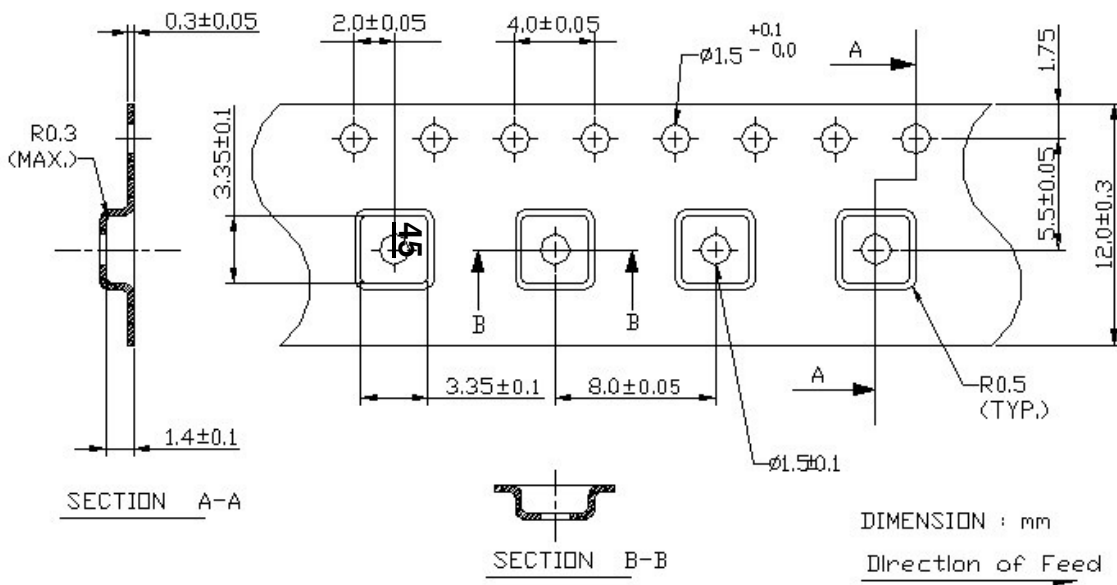

J. RECOMMENDED REFLOW PROFILE:

